

Diesel Generating Set

PP100C

MODEL	PP100C
Standby Power (50Hz)	82KW / 102KVA
Prime Power (50Hz)	75KW / 94KVA

Standard Features

General Features:

Engine (DCEC Cummins 6BT5.9-G1)
 Radiator 50°C max, fans are driven by belt, with safety guard
 24V charge alternator
 Alternator: single bearing alternator IP23, insulation class H/H
 Absorber
 Dry type air filter, fuel filter, oil filter
 Main line circuit breaker
 Standard control panel
 Two 12V batteries, rack and cable
 Ripple flex exhaust pipe, exhaust siphon, flange, muffler
 User manual



PHOTO FOR REFERENCE ONLY

Generator Ratings

Voltage	HZ	Phase	P.F (COS φ)	Standby Amps	Standby Ratings (KW/KVA)	Prime Ratings (KW/KVA)
440/254	50	3	0.8	135	82/102	75/94
415/240	50	3	0.8	143	82/102	75/94
400/230	50	3	0.8	148	82/102	75/94
380/220	50	3	0.8	156	82/102	75/94

Prime Power (PRP): Prime power is available for an unlimited number of annual hours in variable load application, in accordance with GB/T2820 (eqv ISO8528) ; A 10% overload capability is available for a period of 1 hour within a 12-hour period of operation.

Standby Power Rating (ESP): The standby power rating is applicable for supplying emergency power for the duration of a utility power interruption. No overload, utility parallel or negotiated outage operation capability is available at this rating.

Diesel Generating Set**PP100C****ENGINE DATA**

Manufacturer / Model:	DCEC Cummins 6BT5.9-G1, 4-cycle
Air Intake System:	Turbo
Fuel System:	A type fuel pump
Cylinder Arrangement:	6 in line
Displacement:	5.9L
Bore and Stroke:	102*120 (mm)
Compression Ratio:	17.3:1
Rated RPM:	1500rpm
Max. Standby Power at Rated RPM:	92KW/123HP
Governor Type:	RSV Mechanical

Exhaust System

Exhaust Gas Flow:	16.3m ³ /min
Exhaust Temperature:	510°C
Max Back Pressure:	10kPa

Air Intake System

Max Intake Restriction:	6kPa
Burning Capacity:	6.2m ³ /min
Air Flow:	158m ³ /min

Fuel System

100% (Prime Power) Load:	208 g/kWh
75% (Prime Power) Load:	209 g/kWh
50% (Prime Power) Load:	221 g/kWh
100% (Prime Power) Load:	20.8L/h

Oil System

Total Oil Capacity:	16.4L
Oil Consumption:	≤4g/kwh
Engine Oil Tank Capacity:	12.3~14.2L
Oil Pressure at Rated RPM:	345kPa

Cooling System

Total Coolant Capacity:	27L
Max Water Temperature:	104°C

ALTERNATOR SPECIFICATION**GENERAL DATA**

Compliance with GB755, BS5000, VDE0530, NEMAMG1-22, IED34, CSAC22 and AS1359 standards.

ALTERNATOR DATA

Number of Phase:	3
Connecting Type:	3 Phase and 4 Wires, "Y" type connecting
Number of Bearing:	1
Power Factor:	0.8
Protection Grade:	IP23
Altitude:	≤1000m
Exciter Type:	Brushless, self-exciting
Insulation Class, Temperature Rise:	H/H
Telephone Influence Factor (TIF):	<50
THF:	<2%
Alternator Capacity:	100KVA
Alternator Efficiencies:	90.3%

GENERATOR SET DATA

Voltage Regulation:	≥±5%
Voltage Regulation, Stead State:	≤±1%
Sudden Voltage Warp (100% Sudden Reduce):	≤+25%
Sudden Voltage Warp (Sudden Increase):	≤-20%
Voltage Stable Time (100% Sudden Reduce):	≤6S
Voltage Stable Time (Sudden Increase)	≤6S
Frequency Reduce:	≤5%
Frequency Waving:	≤1.5%
Sudden Frequency Warp (100% Sudden Reduce):	≤+12%
Sudden Frequency Warp (Sudden Increase):	≤-10%
Frequency Recovery Time (100% Sudden Reduce):	≤5S
Frequency Recovery Time (Sudden Increase):	≤5S

Diesel Generating Set

PP100C

Standard Features

- ◇ Standard Auto Control System
- ◇ Base Fuel Tank
- ◇ Starting batteries (Maintenance-Free & Watering-Free) with connective wires
- ◇ MCCB
- ◇ Oil Drain Valve
- ◇ Exhaust System (including until muffler)
- ◇ Special tool for Cummins engine
- ◇ One set of fuel filter / oil filter / belt
- ◇ Documents

Options

- ◇ Daily Fuel Tank
- ◇ Battery Charger
- ◇ Engine Heater
- ◇ Alternator Heater
- ◇ Water Separator
- ◇ Permanent Magnet Generator(PMG)
- ◇ Rainproof Type
- ◇ Soundproof Type
- ◇ Trailer Type
- ◇ Remote Control Panel
- ◇ Automatic Transfer Switch
- ◇ Switch box
- ◇ Spare Parts

Dimension & Weight

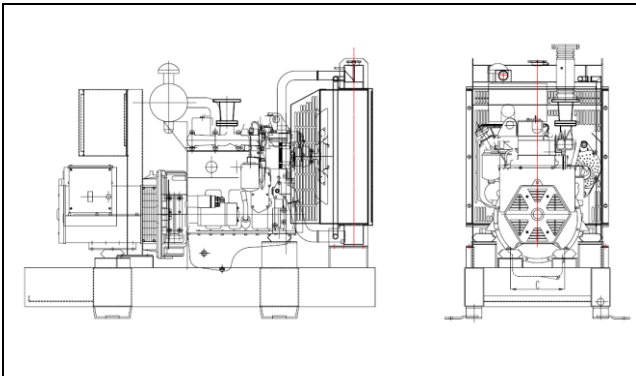

Open Type with Base Fuel Tank

Overall Size: 2350×830×1700 (mm)

Weight: 1310 kg

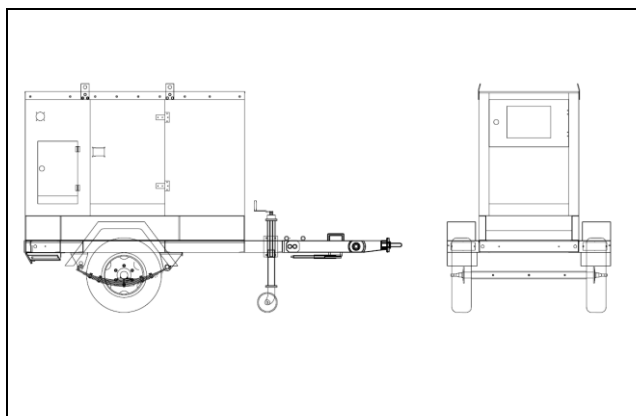

Soundproof Type

Overall Size: 2810×1140×1830 (mm)

Weight: 1800kg

Trailer Type

Overall Size: 3390×1720×2470 (mm)

Weight: 2450kg

Diesel Generating Set

PP100C

Auto Module Control Panel

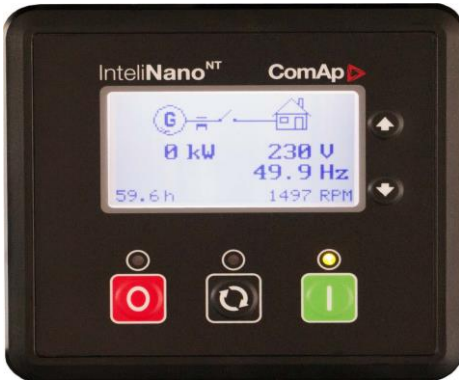

Powergen Pacific Standard Control Panel uses micro processing technique integrating digital, intelligent and network techniques which can carry out functions including auto start/stop, data measure, alarming. The controller uses LCD display. It can be widely used in all types of generator automatic control system for compact structure, advanced circuits, simple connections and high reliability. USB interface and ECU support CAN J1939.

Auto Parallel Control Panel



Automatic Parallel Control Panel This new automatic parallel system adopts intelligent modules, inserted and folded installed, no need the peripheral relay and logic circuit. The main switch adopts electronic breaker or frame breaker, combined together with the generator, which is very reliable. One generator, one panel. The panel can be used both for singly and parallel. It is only need to parallel generator with such panel when the capability needs to be enlarged in the future.

Sales Promises

Powergen Pacific provides a full line of brand new and high quality products. Each unit is strictly factory tested.

Warranty is according to our standard conditions: a, 15 months, counted on the day Powergen Pacific sold to the first buyer; b, One year after installation; c, 1000 running hours (accumulated); subject to the earlier one.

Service and parts are available from Powergen Pacific or distributors in your location.