

Diesel Generating Set

PP1100C

MODEL	PP1100C
Standby Power (50Hz)	880KW / 1100KVA
Prime Power (50Hz)	800KW / 1000KVA

Standard Features

General Features:

Engine (Cummins QSK38-G2)

Radiator 50°C max, fans are driven by belt, with safety guard

24V charge alternator

Alternator: single bearing alternator IP23, insulation class H/H

Absorber

Dry type air filter, fuel filter, oil filter, coolant filter

Main line circuit breaker

Permanent Magnet Generator (PMG)

Standard control panel

12V batteries, rack and cable

Ripple flex exhaust pipe, exhaust siphon, flange, muffler

User manual



PHOTO FOR REFERENCE ONLY

Generator Ratings

Voltage	HZ	Phase	P.F (COS φ)	Standby Amps	Standby Ratings (KW/KVA)	Prime Ratings (KW/KVA)
440/254	50	3	0.8	1443	880/1100	800/1000
415/240	50	3	0.8	1530	880/1100	800/1000
400/230	50	3	0.8	1587	880/1100	800/1000
380/220	50	3	0.8	1671	880/1100	800/1000

Prime Power (PRP): Prime power is available for an unlimited number of annual hours in variable load application, in accordance with GB/T2820 (eqv ISO8528) ; A 10% overload capability is available for a period of 1 hour within a 12-hour period of operation.

Standby Power Rating (ESP): The standby power rating is applicable for supplying emergency power for the duration of a utility power interruption. No overload, utility parallel or negotiated outage operation capability is available at this rating.

Diesel Generating Set**PP1100C****ENGINE DATA**

Manufacturer / Model:	Cummins QSK38-G2, 4-cycle
Air Intake System:	Turbo, Air/Air cooling
Fuel System:	Direct Injection MCRS
Cylinder Arrangement:	12 in "V"
Displacement:	308L
Bore and Stroke:	159*159 (mm)
Compression Ratio:	15:1
Rated RPM:	1500rpm
Max. Standby Power at Rated RPM:	1096KW/1470HP
Governor Type:	Electronic

Exhaust System

Exhaust Gas Flow:	223.5m ³ /min
Exhaust Temperature:	477°C
Max Back Pressure:	7kPa

Air Intake System

Max Intake Restriction:	6.2kPa
Consumption:	93.18m ³ /min
Intake Flow:	1140m ³ /min

Fuel System

100% (Prime Power) Load:	208g/kWh
75% (Prime Power) Load:	221g/kWh
50% (Prime Power) Load:	239g/kWh
100% (Prime Power) Load:	242L/h

Oil System

Total Oil Capacity:	170L
Oil Consumption:	≤4g/kwh
Engine Oil Tank Capacity:	140~167L
Oil Pressure at Rated RPM:	345-483kPa

Cooling System

Total Coolant Capacity:	130L
Max Water Temperature:	104°C

ALTERNATOR SPECIFICATION**GENERAL DATA**

Compliance with GB755, BS5000, VDE0530, NEMAMG1-22, IED34, CSA C22 and AS1359 standards.

ALTERNATOR DATA

Number of Phase:	3
Connecting Type:	3 Phase and 4 Wires, "Y" type connecting
Number of Bearing:	1
Power Factor:	0.8
Protection Grade:	IP23
Altitude:	≤1000m
Exciter Type:	Brushless, self-exciting
Insulation Class, Temperature Rise:	H/H
Telephone Influence Factor (TIF):	<50
THF:	<2%
Alternator Capacity:	1050KVA
Alternator Efficiencies:	95.1%

GENERATOR SET DATA

Voltage Regulation:	≥±5%
Voltage Regulation, Stead State:	≤±1%
Sudden Voltage Warp (100% Sudden Reduce):	≤+20%
Sudden Voltage Warp (Sudden Increase):	≤-15%
Voltage Stable Time (100% Sudden Reduce):	≤4S
Voltage Stable Time (Sudden Increase)	≤4S
Frequency Regulation, Stead State:	≤5% adjustable
Frequency Waving:	≤0.5%
Sudden Frequency Warp (100% Sudden Reduce):	≤+10%
Sudden Frequency Warp (Sudden Increase):	≤-7%
Frequency Recovery Time (100% Sudden Reduce):	≤3S
Frequency Recovery Time (Sudden Increase):	≤3S

Diesel Generating Set

PP1100C

Standard Features

- ◇ COMAP Auto Control System
- ◇ Starting batteries (Maintenance-Free & Watering-Free) with connective wires
- ◇ Exhaust System (including until muffler)
- ◇ MCCB
- ◇ Permanent Magnet Generator(PMG)
- ◇ Documents
- ◇ Special tool for Cummins engine
- ◇ Oil Drain Valve

Options

- ◇ Base Fuel Tank
- ◇ Daily Fuel Tank
- ◇ Battery Charger
- ◇ Engine Heater
- ◇ Water Separator
- ◇ Alternator Heater
- ◇ Soundproof Type
- ◇ Trailer Type
- ◇ Spare Parts
- ◇ Remote Control Panel
- ◇ Automatic Transfer Switch
- ◇ Paralleling System
- ◇ Switch box

Dimension & Weight

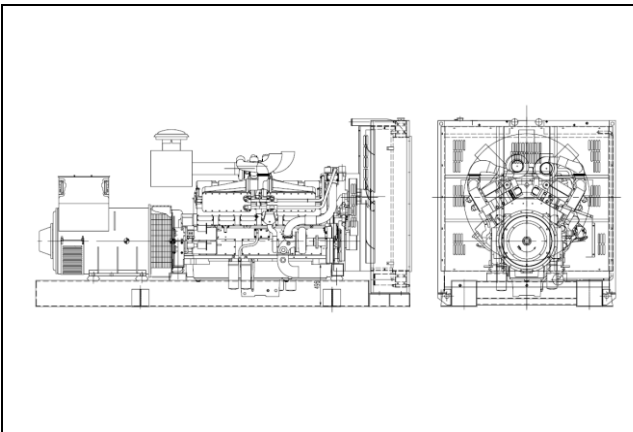

Standard Configuration (Open Type)

Overall Size: 4870x2050x2400 (mm)

Weight: 7650kg

With Base Fuel Tank

Overall Size: 4870x2050x2420 (mm)

Weight: 8350kg

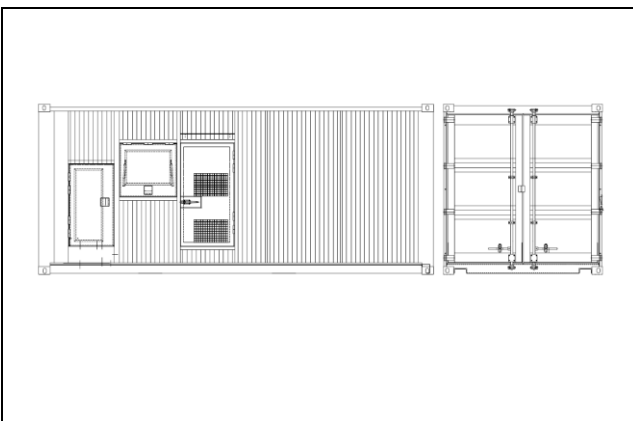

Soundproof Type (20'ft container)

Overall Size: 6058x2438x2591 (mm)

Weight: 13000kg

Diesel Generating Set

PP1100C

Auto Module Control Panel



The automatic generator control panel is the most basic configuration of the unattended automation unit. The screen can receive remote open / stop group control signals.

ComAp MRS10 intelligent controller; large screen LCD, display menu; the unit has automatic, manual, shutdown (emergency stop) and other control functions, rich programmable output, input interface and humanized interface, multi-functional LCD display, test parameters will pass through. The standard communication interface is RS-232 (Modbus communication protocol), which satisfies the requirements of various automation units through communication (network) or central monitoring system (host computer) to realize the functions of remote control, remote measurement, and remote report to the units.

Auto Parallel Control Panel



Automatic Parallel Control Panel This new automatic parallel system adopts intelligent modules, inserted and folded installed, no need the peripheral relay and logic circuit. The main switch adopts electronic breaker or frame breaker, combined together with the generator, which is very reliable. One generator, one panel. The panel can be used both for singly and parallel. It is only need to parallel generator with such panel when the capability needs to be enlarged in the future.

Sales Promises

Powergen Pacific provides a full line of brand new and high quality products. Each unit is strictly factory tested.

Warranty is according to our standard conditions: a, 15 months, counted on the day Powergen Pacific sold to the first buyer; b, One year after installation; c, 1000 running hours (accumulated); subject to the earlier one.

Service and parts are available from Powergen Pacific or distributors in your location.