

## Diesel Generating Set

## PP125C

MODEL	PP125C
Standby Power (50Hz)	100KW / 125KVA
Prime Power (50Hz)	92KW / 115KVA

### Standard Features

#### General Features:

Engine (DCEC Cummins 6BTA5.9-G2)  
 Radiator 50°C max, fans are driven by belt, with safety guard  
 24V charge alternator  
 Alternator: single bearing alternator IP23, insulation class H/H  
 Absorber  
 Dry type air filter, fuel filter, oil filter  
 Main line circuit breaker  
 Standard control panel  
 Two 12V batteries, rack and cable  
 Ripple flex exhaust pipe, exhaust siphon, flange, muffler  
 User manual



PHOTO FOR REFERENCE ONLY

### Generator Ratings

Voltage	HZ	Phase	P.F (COS φ)	Standby Amps	Standby Ratings (KW/KVA)	Prime Ratings (KW/KVA)
440/254	50	3	0.8	164	100/125	92/115
415/240	50	3	0.8	173	100/125	92/115
400/230	50	3	0.8	180	100/125	92/115
380/220	50	3	0.8	189	100/125	92/115

**Prime Power (PRP):** Prime power is available for an unlimited number of annual hours in variable load application, in accordance with GB/T2820 (eqv ISO8528) ; A 10% overload capability is available for a period of 1 hour within a 12-hour period of operation.

**Standby Power Rating (ESP):** The standby power rating is applicable for supplying emergency power for the duration of a utility power interruption. No overload, utility parallel or negotiated outage operation capability is available at this rating.

**Diesel Generating Set****PP125C****ENGINE DATA**

Manufacturer / Model:	DCEC Cummins 6BTA5.9-G2, 4-cycle
Air Intake System:	Turbo, Water/Air Cooling
Fuel System:	PB type fuel pump
Cylinder Arrangement:	6 in line
Displacement:	5.9L
Bore and Stroke:	102*120 (mm)
Compression Ratio:	17.3:1
Rated RPM:	1500rpm
Max. Standby Power at Rated RPM:	116KW/155HP
Governor Type:	Electronic

**Exhaust System**

Exhaust Gas Flow:	20m <sup>3</sup> /min
Exhaust Temperature:	570°C
Max Back Pressure:	10kPa

**Air Intake System**

Max Intake Restriction:	6.1kPa
Burning Capacity:	7.1m <sup>3</sup> /min
Air Flow:	190m <sup>3</sup> /min

**Fuel System**

100% (Prime Power) Load:	211 g/kWh
75% (Prime Power) Load:	212 g/kWh
50% (Prime Power) Load:	219 g/kWh
100% (Prime Power) Load:	25.7L/h

**Oil System**

Total Oil Capacity:	16.3L
Oil Consumption:	≤4g/kwh
Engine Oil Tank Capacity:	12.3~14.2L
Oil Pressure at Rated RPM:	345kPa

**Cooling System**

Total Coolant Capacity:	29L
-------------------------	-----

## **Diesel Generating Set**

**PP125C**

Max Water Temperature:

104°C

### ALTERNATOR SPECIFICATION

#### GENERAL DATA

Compliance with GB755, BS5000, VDE0530, NEMAMG1-22, IED34, CSAC22 and AS1359 standards.

#### ALTERNATOR DATA

Number of Phase:	3
Connecting Type:	3 Phase and 4 Wires, "Y" type connecting
Number of Bearing:	1
Power Factor:	0.8
Protection Grade:	IP23
Altitude:	≤1000m
Exciter Type:	Brushless, self-exciting
Insulation Class, Temperature Rise:	H/H
Telephone Influence Factor (TIF):	<50
THF:	<2%
Alternator Capacity:	120KVA
Alternator Efficiencies:	90.6%

#### GENERATOR SET DATA

Voltage Regulation:	≥±5%
Voltage Regulation, Stead State:	≤±1%
Sudden Voltage Warp (100% Sudden Reduce):	≤+25%
Sudden Voltage Warp (Sudden Increase):	≤-20%
Voltage Stable Time (100% Sudden Reduce):	≤6S
Voltage Stable Time (Sudden Increase)	≤6S
Frequency Regulation, Stead State:	≤5%
Frequency Waving:	≤0.5%
Sudden Frequency Warp (100% Sudden Reduce):	≤+12%
Sudden Frequency Warp (Sudden Increase):	≤-10%
Frequency Recovery Time (100% Sudden Reduce):	≤5S

## Diesel Generating Set

## PP125C

Frequency Recovery Time (Sudden Increase):

≤5S

### Standard Features

- ◇ Standard Auto Control System
- ◇ Base Fuel Tank
- ◇ Starting batteries (Maintenance-Free & Watering-Free) with connective wires
- ◇ MCCB
- ◇ Oil Drain Valve
- ◇ Exhaust System (including until muffler)
- ◇ Special tool for Cummins engine
- ◇ One set of fuel filter / oil filter / belt
- ◇ Documents

### Options

- ◇ Daily Fuel Tank
- ◇ Battery Charger
- ◇ Engine Heater
- ◇ Alternator Heater
- ◇ Water Separator
- ◇ Permanent Magnet Generator(PMG)
- ◇ Rainproof Type
- ◇ Soundproof Type
- ◇ Trailer Type
- ◇ Spare Parts
- ◇ Remote Control Panel
- ◇ Automatic Transfer Switch
- ◇ Switch box
- ◇ Paralleling System

### Dimension & Weight

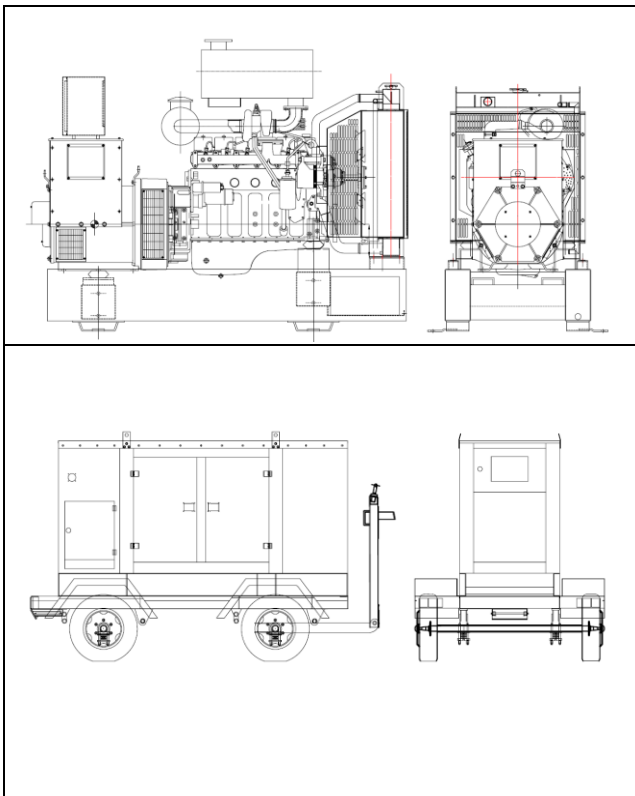

#### Open Type with Base Fuel Tank

Overall Size: 2350×830×1700 (mm)

Weight: 1340 kg

#### Soundproof Type

Overall Size: 3250×1170×1800 (mm)

Weight: 2050kg

#### Trailer Type

Overall Size: 4030×2140×2510 (mm)

Weight: 2950kg

## Diesel Generating Set

## PP125C

### Auto Module Control Panel

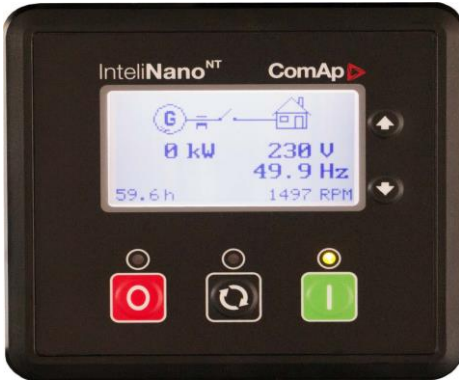

Powergen Pacific Standard Control Panel uses micro processing technique integrating digital, intelligent and network techniques which can carry out functions including auto start/stop, data measure, alarming. The controller uses LCD display. It can be widely used in all types of generator automatic control system for compact structure, advanced circuits, simple connections and high reliability. USB interface and ECU support CAN J1939.

### Auto Parallel Control Panel



**Automatic Parallel Control Panel** This new automatic parallel system adopts intelligent modules, inserted and folded installed, no need the peripheral relay and logic circuit. The main switch adopts electronic breaker or frame breaker, combined together with the generator, which is very reliable. One generator, one panel. The panel can be used both for singly and parallel. It is only need to parallel generator with such panel when the capability needs to be enlarged in the future.

### Sales Promises

Powergen Pacific provides a full line of brand new and high-quality products. Each unit is strictly factory tested.

Warranty is according to our standard conditions: 12 months or 1000 working hours from the shipment date, whichever comes first

Service and parts are available from Powergen Pacific or distributors in your location.