

Diesel Generating Set

PP375C

MODEL	PP375C
Standby Power (50Hz)	300KW/375KVA
Prime Power (50Hz)	275KW/344KVA

Standard Features

General Features:

Engine (CCEC Cummins NTA855-G2A)

Radiator 40°C max, fans are driven by belt, with safety guard

24V charge alternator

Alternator: single bearing alternator IP23, insulation class H/H

Absorber

Dry type air filter, double fuel filter, oil filter, coolant filter

Main line circuit breaker

Standard control panel

Two 12V batteries, rack and cable

Ripple flex exhaust pipe, exhaust siphon, flange, muffler

User manual



PHOTO FOR REFERENCE ONLY

Generator Ratings

Voltage	HZ	Phase	P.F (COS ϕ)	Standby Amps	Standby Ratings (KW/KVA)	Prime Ratings (KW/KVA)
440/254	50	3	0.8	492	300/375	275/344
415/240	50	3	0.8	529	300/375	275/344
400/230	50	3	0.8	541	300/375	275/344
380/220	50	3	0.8	569	300/375	275/344

Prime Power (PRP): Prime power is available for an unlimited number of annual hours in variable load application, in accordance with GB/T2820 (eqv ISO8528) ; A 10% overload capability is available for a period of 1 hour within a 12-hour period of operation.

Standby Power Rating (ESP): The standby power rating is applicable for supplying emergency power for the duration of a utility power interruption. No overload, utility parallel or negotiated outage operation capability is available at this rating.

Diesel Generating Set**PP375C****ENGINE DATA**

Manufacturer / Model:	CCEC Cummins NTA855-G2 A, 4-cycle
Air Intake System:	Turbo, Water/Air cooling
Fuel System:	PT type fuel pump, EFC
Cylinder Arrangement:	6 in line
Displacement:	14L
Bore and Stroke:	140*152 (mm)
Compression Ratio:	14.0:1
Rated RPM:	1500rpm
Max. Standby Power at Rated RPM:	343KW/466HP
Governor Type:	Electronic

Exhaust System

Exhaust Gas Flow:	65.7m ³ /min
Exhaust Temperature:	558°C
Max Back Pressure:	10kPa

Air Intake System

Max Intake Restriction:	10kPa
Consumption:	24.06m ³ /min
Air Flow:	490m ³ /min

Fuel System

100% (Prime Power) Load:	191.3g/kWh
75% (Prime Power) Load:	194.9g/kWh
50% (Prime Power) Load:	207.1g/kWh
100% (Prime Power) Load:	69.5 L/h

Oil System

Total Oil Capacity:	38.6L
Oil Consumption:	≤0.24L/h
Engine Oil Tank Capacity:	28.4~36L
Oil Pressure at Rated RPM:	241-345kPa

Cooling System

Total Coolant Capacity:	85L
Max Water Temperature:	104°C

ALTERNATOR SPECIFICATION**GENERAL DATA**

Compliance with GB755, BS5000, VDE0530, NEMAMG1-22, IED34, CSA C22 and AS1359 standards.

ALTERNATOR DATA

Number of Phase:	3
Connecting Type:	3 Phase and 4 Wires, "Y" type connecting
Number of Bearing:	1
Power Factor:	0.8
Protection Grade:	IP23
Altitude:	≤1000m
Exciter Type:	Brushless, self-exciting
Insulation Class, Temperature Rise:	H/H
Telephone Influence Factor (TIF):	<50
THF:	<2%
Alternator Capacity:	360KVA
Alternator Efficiencies:	93.3%

GENERATOR SET DATA

Voltage Regulation:	≥±5%
Voltage Regulation, Stead State:	≤±1%
Sudden Voltage Warp (100% Sudden Reduce):	≤+25%
Sudden Voltage Warp (Sudden Increase):	≤-20%
Voltage Stable Time (100% Sudden Reduce):	≤6S
Voltage Stable Time (Sudden Increase)	≤6S
Frequency Regulation, Stead State:	≤5%
Frequency Waving:	≤0.5%
Sudden Frequency Warp (100% Sudden Reduce):	≤+12%
Sudden Frequency Warp (Sudden Increase):	≤-10%
Frequency Recovery Time (100% Sudden Reduce):	≤5S
Frequency Recovery Time (Sudden Increase):	≤5S

Diesel Generating Set

PP375C

Standard Features

- ◇ Standard Auto Control System
- ◇ Starting batteries (Maintenance-Free & Watering-Free) with connective wires
- ◇ Documents
- ◇ MCCB
- ◇ Oil Drain Valve
- ◇ Special tool for Cummins engine
- ◇ Exhaust System(including until muffler)

Options

- ◇ Base Fuel Tank
- ◇ Daily Fuel Tank
- ◇ Battery Charger
- ◇ Engine Heater
- ◇ Water Separator
- ◇ Permanent Magnet Generator(PMG)
- ◇ Alternator Heater
- ◇ Rainproof Type
- ◇ Soundproof Type
- ◇ Trailer Type
- ◇ Remote Control Panel
- ◇ Automatic Transfer Switch
- ◇ Paralleling System
- ◇ Switch box
- ◇ Spare Parts

Dimension & Weight

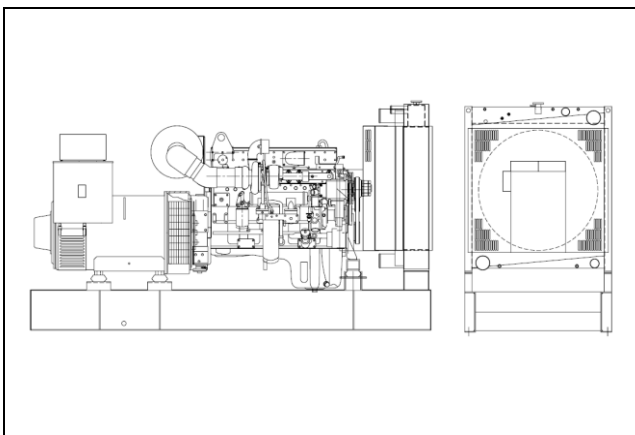

Standard Configuration (Open Type)

Overall Size: 3030×1100×1850 (mm)

Weight: 2870kg

With Base Fuel Tank

Overall Size: 3030×1100×1900 (mm)

Weight: 3000kg

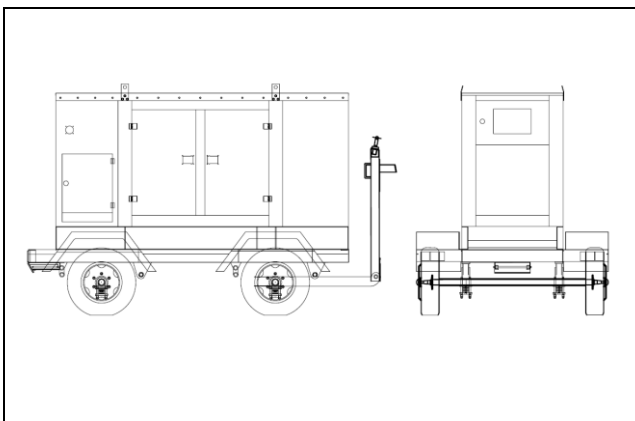

Soundproof Type

Overall Size: 4225×1460×2150 (mm)

Weight: 4330kg

Trailer Type

Overall Size: 5030×2440×2880 (mm)

Weight: 5690kg

Diesel Generating Set

PP375C

Auto Module Control Panel

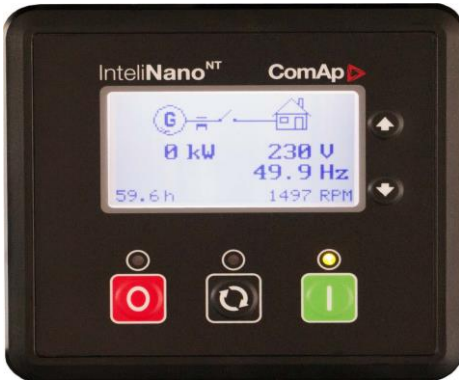

Powergen Pacific Standard Control Panel uses micro processing technique integrating digital, intelligent and network techniques which can carry out functions including auto start/stop, data measure, alarming. The controller uses LCD display. It can be widely used in all types of generator automatic control system for compact structure, advanced circuits, simple connections and high reliability. USB interface and ECU support CAN J1939.

Auto Parallel Control Panel



Automatic Parallel Control Panel This new automatic parallel system adopts intelligent modules, inserted and folded installed, no need the peripheral relay and logic circuit. The main switch adopts electronic breaker or frame breaker, combined together with the generator, which is very reliable. One generator, one panel. The panel can be used both for singly and parallel. It is only need to parallel generator with such panel when the capability needs to be enlarged in the future.

Sales Promises

Powergen Pacific provides a full line of brand new and high quality products. Each unit is strictly factory tested.

Warranty is according to our standard conditions: a, 15 months, counted on the day Powergen Pacific sold to the first buyer; b, One year after installation; c, 1000 running hours (accumulated); subject to the earlier one.

Service and parts are available from Powergen Pacific or distributors in your location.